

Insulated Gate Bipolar Transistor Silicon N Channel IGBT

JB75N065JP3

This Insulated Gate Bipolar Transistor (IGBT) features a robust and cost effective. Provides superior performance in demanding switching applications, offering both low on state voltage and minimal switching loss.

Features

- Enhancement mode type
- Low saturation voltage : $V_{CE}(\text{sat}) = 1.65 \text{ V (Typ)} (I_C = 75 \text{ A})$

Typical Applications

- For industrial UPS and solar applications

Absolute Maximum Ratings (Ta=25°C)

Parameter	Symbol	Value	Unit
Collector-emitter voltage	V_{CE}	650	V
DC collector current, limited by T_{jmax}	I_C	150	A
$T_C = 25^\circ\text{C}$		75	
$T_C = 100^\circ\text{C}$	I_{Cpuls}	225	A
Pulsed collector current, tp limited by T_{jmax}			
Gate-emitter voltage	V_{GE}	± 20	V
Transient Gate-emitter voltage (tp $\leq 10\mu\text{s}$, D < 0.010)		± 30	
Power dissipation $T_C = 25^\circ\text{C}$	PD	280	W
Power dissipation $T_C = 100^\circ\text{C}$		140	
Operating junction temperature	T_j	-40 to +175	°C
Storage temperature	T_{stg}	-55 to +175	°C

1. Using continuously under heavy loads (e.g. the application of high temperature/current/voltage and the significant change in temperature, etc.) may cause this product to decrease in the reliability significantly even if the operating conditions (i.e. operating temperature/current/voltage, etc.) are within the absolute maximum ratings.
 2. The specifications described are tentative and subject to change without notice.

Pinning information

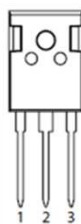
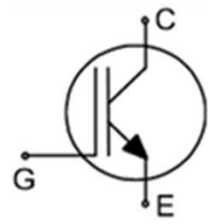
Pin	Symbol	Description	Simplified outline	Graphic symbol
1	G	Gate		
2	C	Collector		
3	E	Emitter		

ELECTRICAL CHARACTERISTICS (T_j= 25°C unless otherwise specified)

IGBT

Characteristics		Symbol	Test Condition	Min	Typ	Max	Unit
Gate leakage current		I _{GES}	V _{GE} =±30 V, V _{CE} =0	—	—	±500	nA
Collector cut-off current		I _{CES}	V _{CE} = 650V, V _{GE} =0V	—	—	10	uA
Gate-emitter cut-off voltage		V _{GE (OFF)}	I _C = 40mA, V _{CE} = 5V	5.7	6.7	7.7	V
Collector-emitter saturation voltage	T _j =25°C	V _{CE (sat)}	I _C = 75A, V _{GE} = 15V	—	1.65	1.95	V
	T _j =100°C			—	2.0	—	
Gate-emitter threshold voltage		V _{GE(th)}	V _{GE} = V _{CE} , I _C = 350μA	4.8	5.8	6.8	V
Input capacitance		C _{ies}	V _{CE} =25V, V _{GE} = 0V, f = 1MHz	—	8300	—	pF
Output capacitance		C _{oes}		—	215	—	
Reverse transfer capacitance		C _{res}		—	210	—	
Switching time	Rise time	t _r	T _j = 25 °C V _{CE} = 300V, V _{GE} = 0V/15V, R _G = 10Ω, I _C = 75A, L=100μH	—	120	—	ns
	Turn-on time	t _{d(on)}		—	120	—	
	Fall time	t _f		—	80	—	
	Turn-off time	t _{d(off)}		—	420	—	
Thermal Resistance		R _{th (j-c)}		—	—	0.54	°C / W

1.The specifications described are tentative and subject to change without notice.

2.Product parametric performance is indicated in the Electrical Characteristics for the listed test conditions, unless otherwise noted. Product performance may not be indicated by the Electrical Characteristics if operated under different conditions.

TENTATIVE

JB75N065JP3

Power Dissipation vs. Case Temperature

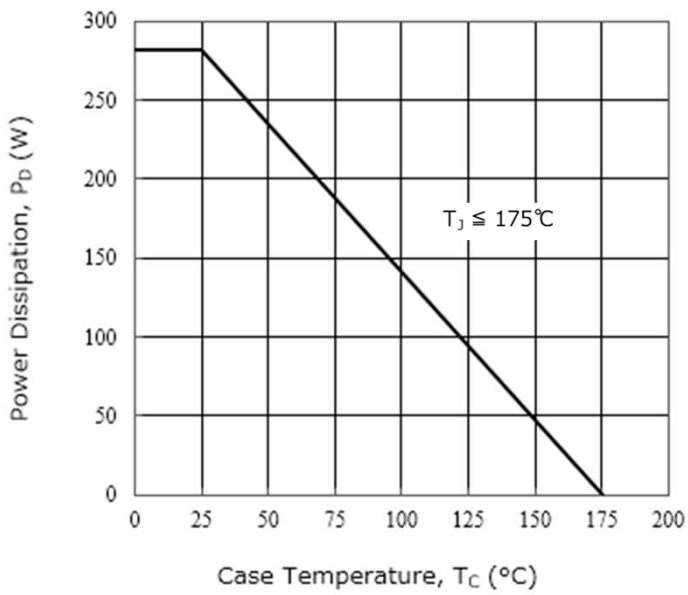

Output Characteristics

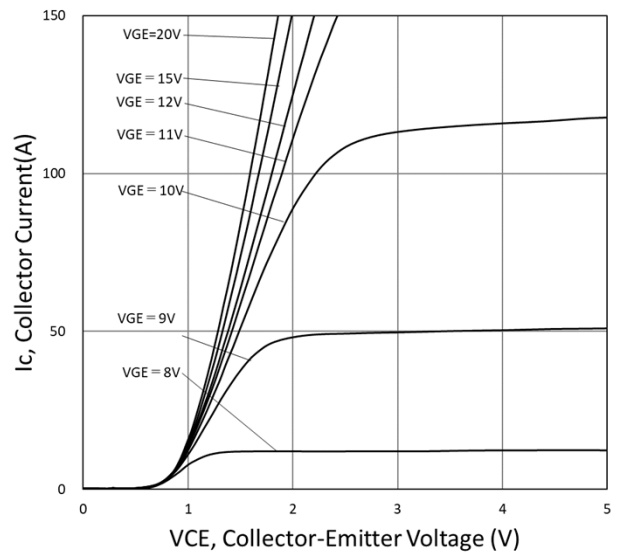

Gate Threshold Voltage ($I_C=40mA$, $V_{CE}=5V$)

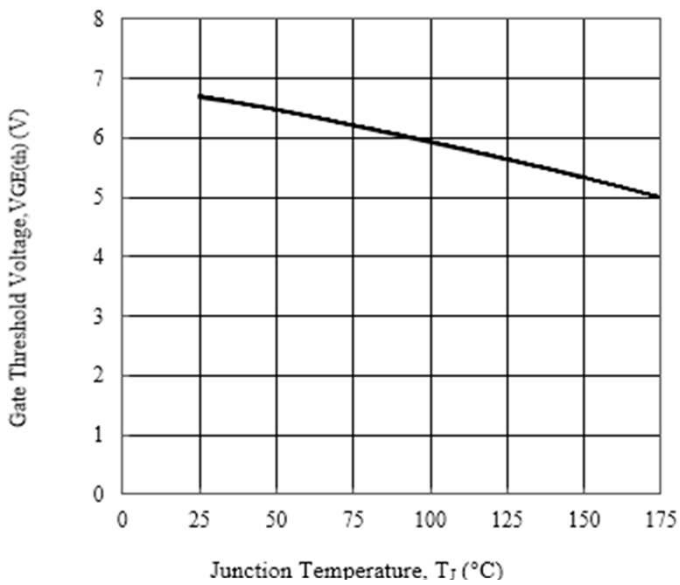

Transfer Characteristics ($V_{CE}=5V$)

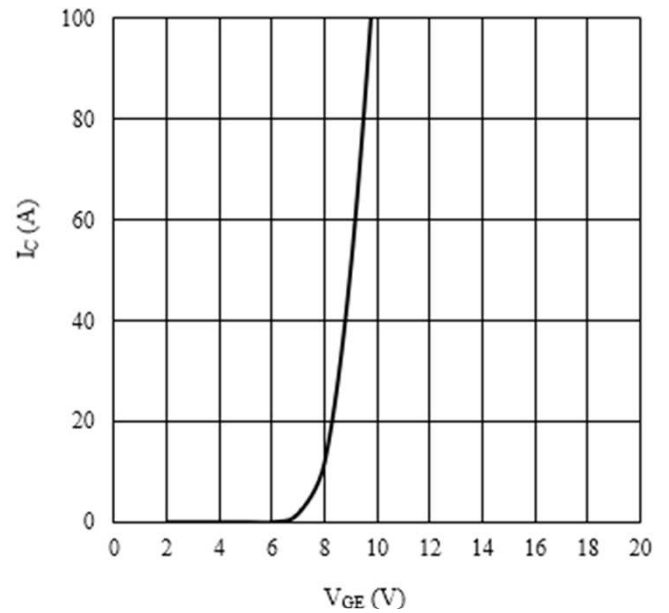

Capacitance Characteristics

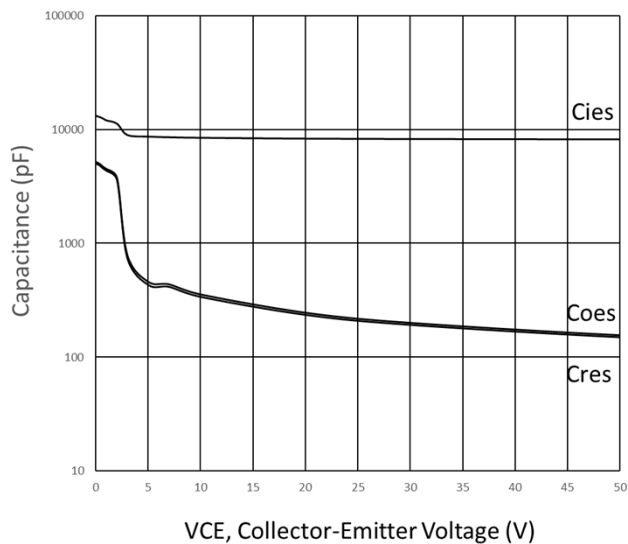

Safe Operating Area

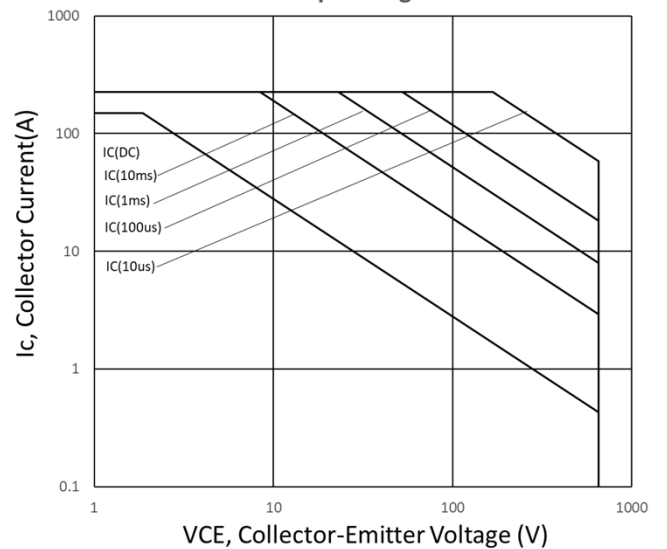

JB75N065JP3

Outline drawing [Dimensions are in MILLIMETERS]

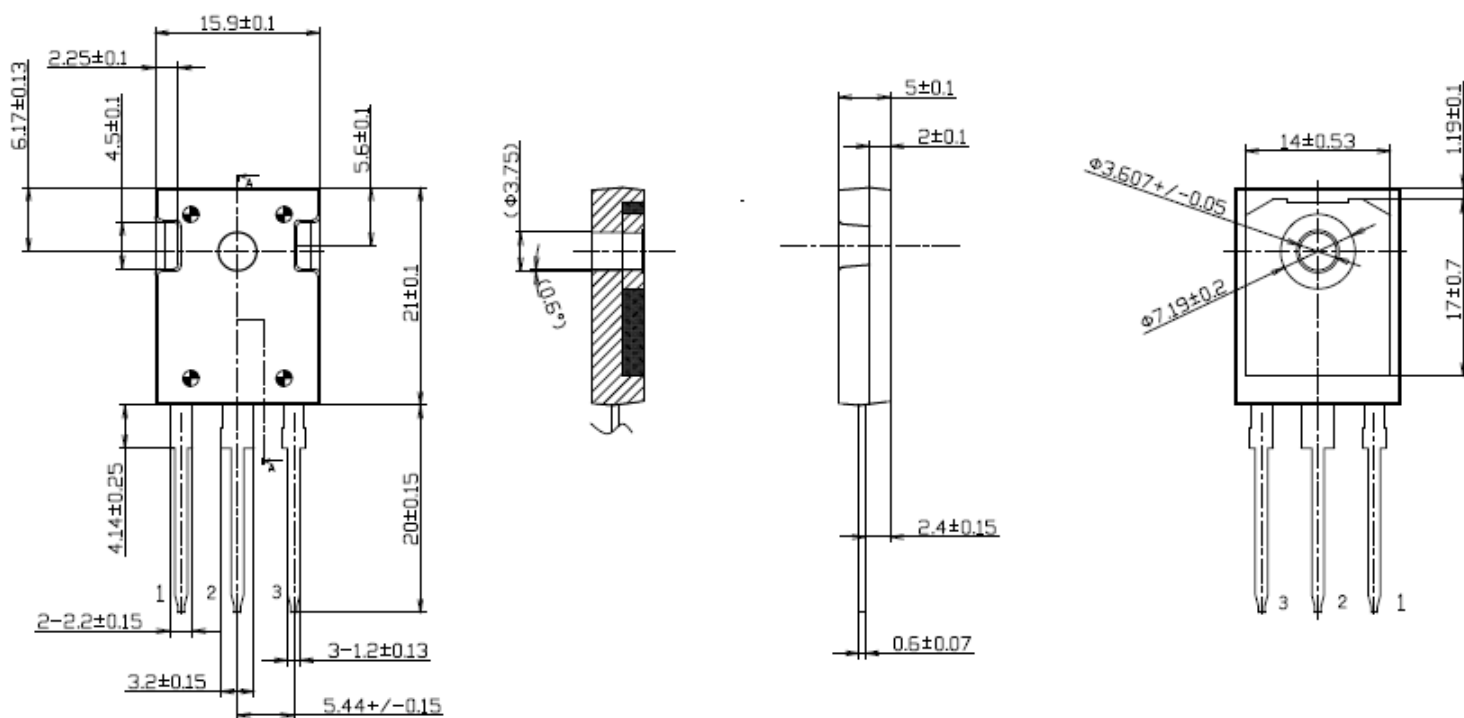

CONNECTION

- ①: Gate terminal
- ②: Collector terminal
- ③: Emitter terminal

Cautions

Please ensure insulation between the heat sink and the product before use.
 The collector potential on the backside of the products is not intended to be used as a conduction path.

JB75N065JP3

Warning

- 1.The information contained herein is subject to change without notice.
- 2.Before you use our Products, please contact our sales representative and verify the latest specifications.
- 3.Although Japan Power Device Co., Ltd.(hereinafter JPD) is enhancing product quality and reliability, semiconductors can break down and malfunction due to various factors. When using JPD products in your equipment, in order to prevent personal injury or fire arising from failure, please take safety measures such as complying with the derating characteristics, implementing redundant and fire prevention designs, and fail-safe procedures.
JPD shall have no responsibility for any damages arising out of the use of our Products beyond the rating specified by JPD.
- 4.The product described in this Data sheet are intended for use in the following electronic and electrical equipment which has normal reliability requirements.
- 5.The product described in this Data sheet is not designed nor made for being applied to the systems used under life-threatening situations.
The product described in this Data sheet is not designed to be radiation tolerant.
- 6.For use of our Products in applications requiring a high degree of reliability (as exemplified below), please contact and consult with a JPD representative : transportation equipment (i.e.cars, ships, trains), primary communication equipment, traffic lights, fire/crime prevention.
- 7.Do not use our Products in applications requiring extremely high reliability, such as aerospace equipment, nuclear power control systems, and submarine repeaters.
8. This product shall be used within its maximum rating (voltage, current, temperature, and so on) described in this specification. This product may be broken in case of using beyond the maximum ratings.The specified value in the absolute maximum ratings are guaranteed value for the rating, not for any combination of ratings or characteristics. Please refer to the absolute maximum rating of this product, and judge the suitability of this product for your system / equipment after evaluation and verification by yourself.
JPD shall have no responsibility for any damages or injury arising from non compliance with the recommended usage conditions and specifications contained herein.
- 9.JPD has used reasonable care to ensure the accuracy of the information contained in this document. However, JPD does not warrants that such information is error-free, and JPD shall have no responsibility for any damages arising from any inaccuracy or misprint of such information
10. You shall not use this product for military purposes, such as developing weapons of mass destruction, or for any other military purpose. In addition, you must comply with all export-related laws and regulations, such as the "Foreign Exchange and Foreign Trade Act"and the "U.S.Export Administration Regulations", and follow the procedures required by these laws and regulations. JPD shall have no responsibility for any damages or losses resulting non-compliance with any applicable laws or regulations.
- 11.This Data sheet does not warranty the continuous production or supply of the product.
- 12.This document, in part or in whole, may not be reprinted or reproduced without prior consent of JPD.
- 13.If you have any question about any portion in this Catalog, JPD or its sales agents before using the product. JPD nor its agents shall be liable for any injury caused by any use of the products not in accordance with instructions set forth herein.